

## 15 Maintenance and care

Have your mailing system cleaned and serviced regularly by an authorized Service staff. This guarantees long-term, trouble-free operation. Ask about available maintenance agreements.

You can do the following work yourself:

- Clean housing exterior
- Clean sensors
- Clean print system
- Change ink cartridge
- Replace transport brush
- Calibrate touch screen
- Filling with sealing fluid (*feeder / sealer*)
- Clean / replace moistening sponge (*feeder*)
- Clean / replace moistening brush (*feeder*)
- Clean / replace felts (*sealer*).

### 15.1 Cleaning the housing



**Warning! Electrical hazard.** Disconnect the power plug before cleaning the mailing system.



**Warning! Electrical hazards due to short circuits.** Be extremely careful when handling fluids. Take special care that no foreign objects penetrate the system's interior. If this should happen, have the mailing system checked by FP Customer Service before using it again.

---

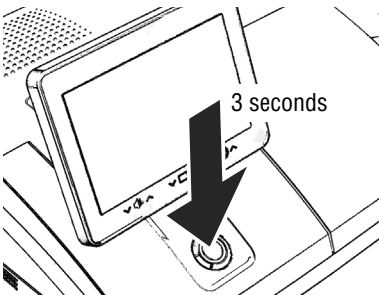

- Turn PostBase Vision off.
- Pull the power plugs of the postage meter and of all peripherals such as the feeder out of the outlet.
- Clean dirt from the housing with a slightly damp cloth. You can also use a commercially available dishwashing detergent.

## 15.2 Cleaning the sensors

Over time, paper dust may deposit on the sensors of the mailing system and cause problems with the letter detection. In order to ensure faultless operation at all times, we recommend cleaning the sensors once a month. A special compressed air spray for cleaning the sensors is available from FP.

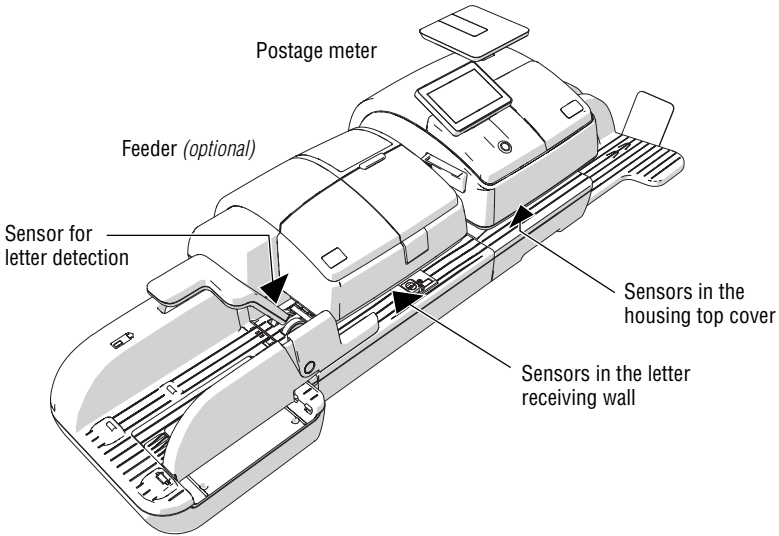

### How to clean the sensors

- Turn PostBase Vision off.

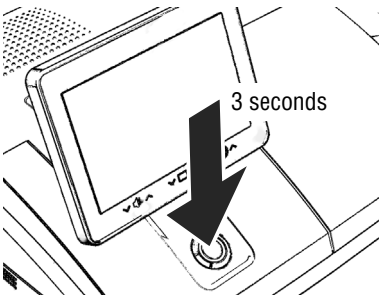

## On the postage meter



**Caution!** Ink residue may be present on the drawer. Make sure you do not get ink on yourself, or stain your clothing and other objects. Place the drawer down on a base surface.

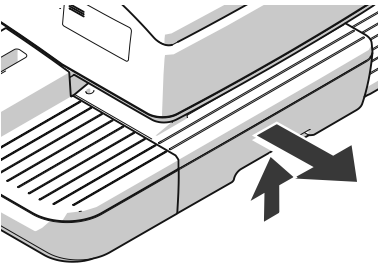

- Unlock the drawer: Push the drawer latch lever upwards.
- Pull the drawer to the front, out of the housing.
- Place the drawer on an underlay.

The flashing LEDs in the letter entrance area indicate the drawer is missing.

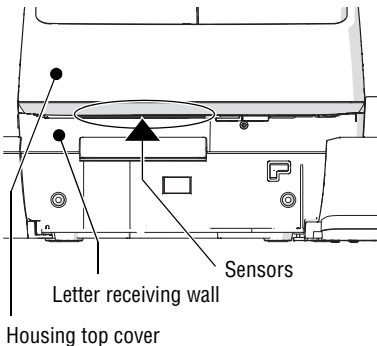

The sensors are now accessible from below. They are located right inside the bottom section of the housing.

- Remove the dust from the sensor area with a few puffs of the compressed air spray.

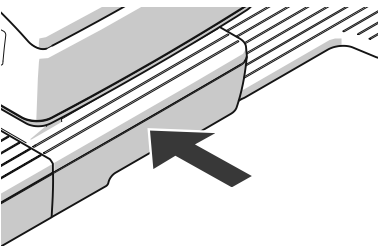

- Slide the drawer in to the stop. Make sure that the drawer latches correctly on both sides.

When the drawer is correctly inserted, the LEDs in the letter entrance area will go out. PostBase Vision is ready to operate again.

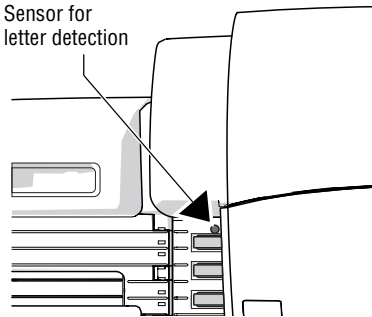

### On the feeder

The sensor for the letter detection is freely accessible.

- Remove the dust from the sensor with a few puffs of the compressed air spray.

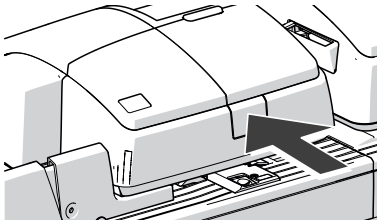

- Press the release button.

The roller transport moves upwards.

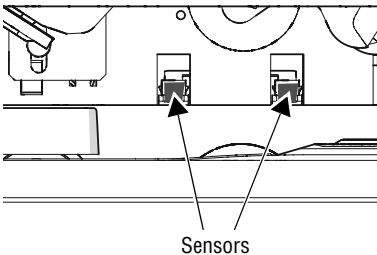

The sensors in the letter receiving wall are now accessible from the front (operator side).

- Remove the dust from the sensors with a few puffs of the compressed air spray.

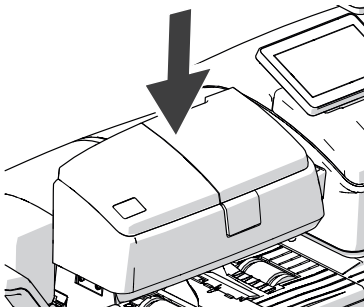

- Press down firmly on the roller transport until it clicks into place.

## 15.3 Cleaning the print system

### 15.3.1 Starting automatic print system cleaning

You should start automatic print system cleaning only if the quality of the imprint is not good enough (e.g. blank spots in the imprint after longer periods out of use).



#### Cleaning

- Open the MENU.
- Choose INK CARTRIDGE.
- Choose CLEANING.

A message informs you about the cleaning process in progress.

- Confirm the message with OK.
- Check the quality of the imprint with a Test Imprint (see chapter 15.4).

#### Intensive cleaning

You should start intensive cleaning if normal cleaning fails to improve the print quality to your satisfaction.



- Open the MENU.
- Choose INK CARTRIDGE.
- Choose INTENSIVE CLEANING.

A message informs you about the cleaning process in progress.

- Confirm the message with OK.
- Check the quality of the imprint with a Test Imprint (see chapter 15.4).



In case of stubborn soiling, even intensive cleaning may be unable to improve the print quality as desired. In such cases, you can manually clean the cartridge. Read the following chapter.

### 15.3.2 Cleaning the ink cartridge manually



**Caution!** Improper cleaning can damage the ink cartridge and render it useless. Note the following hints to avoid damage to the print system:

- In case of print quality issues, always run the automatic cleaning functions first. Read chapter 15.3.1 on page 129.
- You should manually clean the ink cartridge in exceptional cases only where intensive cleaning fails to restore the normal print quality.
- For cleaning, make sure to use a soft, lint free cloth moistened with demineralized water. Small fibers could clog the nozzles. Too hard or dry cloths could scratch the nozzle plate. Such scratches render the ink cartridge useless because they prevent the ink-jet from being correctly positioned during printing.
- Never use any chemical cleansers.



#### Removing the cartridge

- Open the MENU.
- Choose INK CARTRIDGE.
- Choose CHANGE CARTRIDGE.
- Remove the ink cartridge.  
For details, please refer to chapter “Changing the ink cartridge”, starting on page 135.

#### Cleaning

- Moisten a lint free cloth with demineralized water.



You can also use distilled water or normal tap water if demineralized water is not available. The minerals contained in tap water could, however, leave residues in the print head.



For best cleaning results, use FP contact cleaner and cleaning cloths contained in the clean & renew cleaning kit offered by FP.

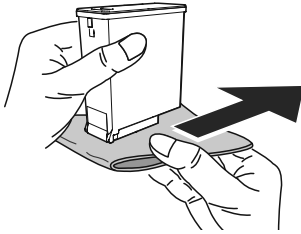

- Hold the cartridge as shown in the picture. The nozzles must point downwards!
- Slowly and carefully wipe the print head with the cloth in the direction of the arrow. Repeat this action several times.

The water will blend with ink residues and clean the nozzles.

- Reinsert the cartridge (see page 137).
- Close the flap of the print system (see page 138).

## 15.4 Test Imprint – Check print quality

Using the menu function “Test Imprint”, you can test the functioning of the print system and check the print quality. The generated test print consists of a series of different patterns.



- Open the MENU.
- Choose INK CARTRIDGE.
- Choose TEST IMPRINT.

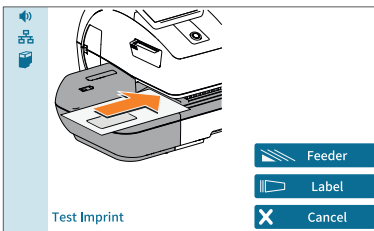

PostBase Vision prompts you to position a letter.

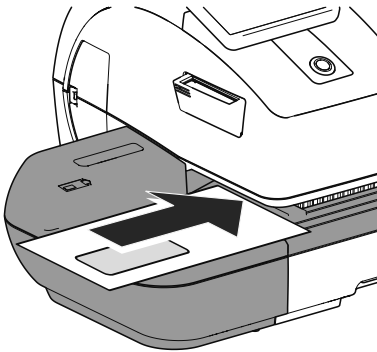

### Print Test Imprint on an empty envelope

- Place an empty envelope (or a postcard) on the hand feed tray.

*Or*

- Place an empty envelope (or a postcard) on the feeder (*optional*).

PostBase Vision feeds the envelope and prints the Test Imprint consisting of a series of different plane and line patterns.

### Print Test Imprint on a label

- Tap the LABEL button.

PostBase Vision prints the Test Imprint on a label.



### Check print quality

Make sure PostBase Vision always produces clean and legible meter imprints.

- Check the print quality. There must not be any blurred or blank spots.



This illustration shows a perfect imprint.



When there are blurred or blank spots in the imprint:

- Clean print system. Read chapter 15.3 on page 129.

## 15.5 Print system: show ink level

The approximate ink level of the cartridge is shown by the icon in the menu bar (full, 75%, 50%, 25%, empty). With this feature, you can track ink consumption at a glance. You can also view the ink level as a percentage in the INK CARTRIDGE menu.



- Open the MENU.
- Choose INK CARTRIDGE.
- Choose INK LEVEL.

PostBase Vision displays the ink cartridge's filling level as a percentage.

## 15.6 Changing the ink cartridge

PostBase Vision monitors the ink level of the cartridge and issues a message when it must be replaced. We recommend that you always have a new ink cartridge in stock.

We advice to clean the contacts in the cartridge bracket at each cartridge replacement. Use the special “clean & renew” cleaning kit for PostBase Vision, available from FP.



**Caution!** *The ink contains small quantities of components that are hazardous to health and may cause eye, skin and respiratory irritation and allergic reactions. Ink may be harmful if swallowed.*

- *Avoid eye and skin contact with the ink.*
- *Avoid inhaling ink fumes.*
- *Avoid swallowing the ink.*
- *Keep out of reach of children.*



**Caution!** *Note the following hints to avoid damage to the print system:*

- *Do not attempt to manually open the ink cartridge flap (cover) of the machine. To open, go to the MENU on the PostBase Vision and then select INK CARTRIDGE and CHANGE CARTRIDGE and the flap will automatically open.*
  - *We recommend to use only approved FP equipment and FP original parts. The manufacturer FP has established reliability, safety and applicability. The manufacturer cannot assess the reliability, safety and applicability for products not approved by FP, and therefore not vouch for such products.*
  - *Always use a brand new ink cartridge.*
  - *The clip attached to some ink cartridges as transportation protection is intended for single use only. Ideally dispose of the clip immediately. Never put the clip back on the cartridge in order to prevent damage to the print nozzle plate, which can cause short circuits, overheating and melting of components.*
-



## Changing the ink cartridge

- Open the MENU.
- Choose INK CARTRIDGE.
- Choose CHANGE CARTRIDGE.

**Note:** Do not lean on the flap of the print system or otherwise hinder it from opening automatically.

The replacement procedure starts. PostBase Vision moves the ink cartridge to the exchange position and opens the flap.

- Follow the instructions on the display. The screen sequence demonstrates the procedure of changing the cartridge.

The required steps are described in detail below.

## Removing the ink cartridge



**Caution!** There is ink residue on the used ink cartridge. Take care not to stain yourself, clothing or objects. Use a mat to place the ink cartridge.

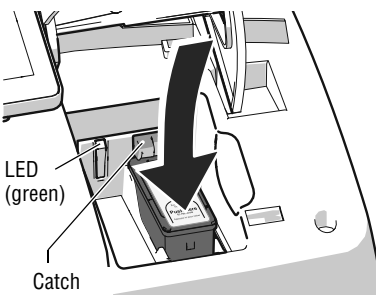

- Slightly push the cartridge down on the “Push here ...” mark. In doing so, the cartridge tilts to the front. The cartridge is unlatched. The green LED flashes.
- Ease off against the spring pressure and let the cartridge slide upwards, past the green catch.

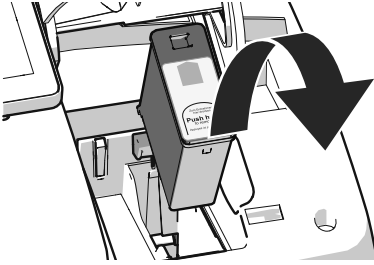

- Take the ink cartridge upward and out of the socket.

### Inserting new ink cartridge

The full functioning of the PostBase Vision mailing system at the time of delivery can only be guaranteed when using genuine FP ink cartridges.



---

**Caution!** Insert the ink cartridge only after it has adapted to the ambient temperature of the PostBase Vision (e.g. after storage in the basement or after transport in a cold vehicle).

---

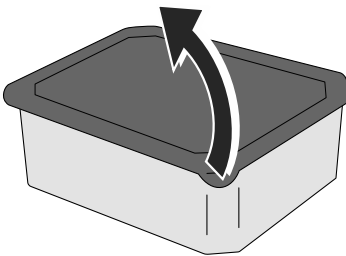

- Open the cartridge packaging.
- Remove the ink cartridge from its packaging.

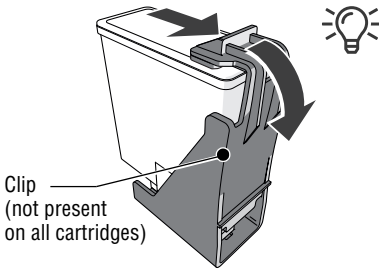

**Note:** Depending on the model, the ink cartridge may be fitted with a clip that acts as a transportation protection.

If the ink cartridge has such a clip:

- Remove the clip.

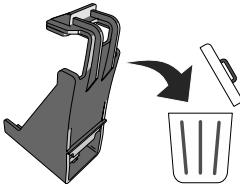

- Dispose of the clip.

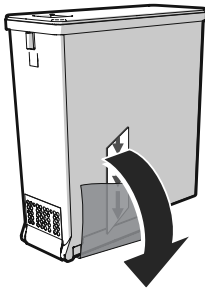

- Pull off the protective strip (nozzle protection).

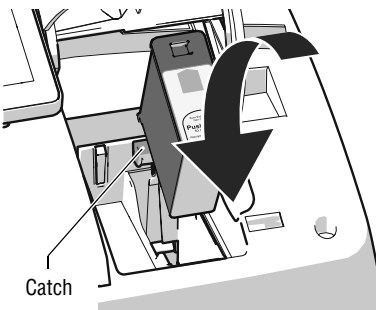

- Hold the ink cartridge with its connectors facing backwards, i.e. towards the back of PostBase Vision. The green arrow on the cartridge points towards the green catch on the cartridge bracket.
- Insert the ink cartridge into its bracket.
- Push down the ink cartridge and let it snap to the back, under the catch.

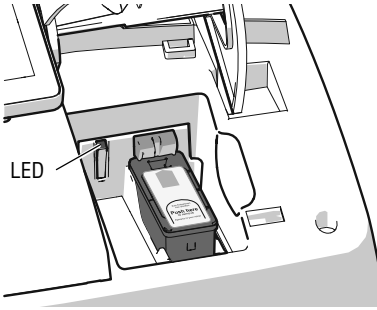

When the cartridge is inserted correctly, the green LED glows continuously.

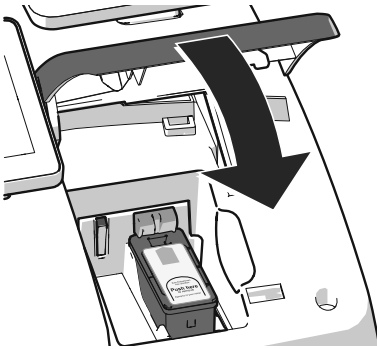

- Close the flap of the print system:  
Push down the flap in the area of the PostBase Vision logo until the latch catches.

*Preparing for operation*

After changing the ink cartridge, PostBase Vision internally prepares the cartridge for operation. Please be patient until this process is complete.



We recommend checking the print quality by performing a Test Imprint (see chapter 15.4).

## 15.7 Replacing the transport brush

When imprints on thin letters or labels appear compressed, the transport brush needs to be replaced.

**! Caution!** As long as the print system is in printing position, the drawer is locked. Do not pull out the drawer by force. Wait until the print system moves into idle position, then remove the drawer.

**! Caution** Ink residue may be present on the drawer. Make sure you do not get ink on yourself, or stain your clothing and other objects. Place the drawer down on a base surface.

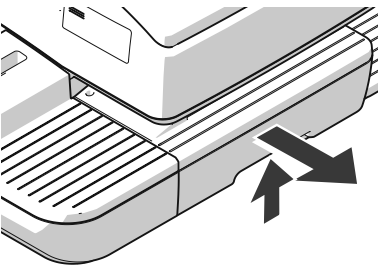

- Unlock the drawer: Push the drawer latch lever upwards.
- Pull the drawer to the front, out of the housing.
- Place the drawer on an underlay.

The flashing LEDs in the letter entrance area indicate the drawer is missing.

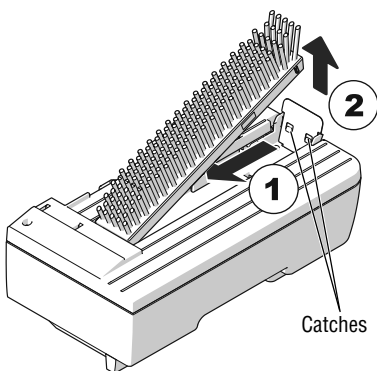

### Remove worn-out transport brush

The transport brush is held in the brush carrier by two catches on the right side.

- Grab the bristles, pull the worn-out transport brush to the left to unlock it and pull it upwards out of the brush carrier.

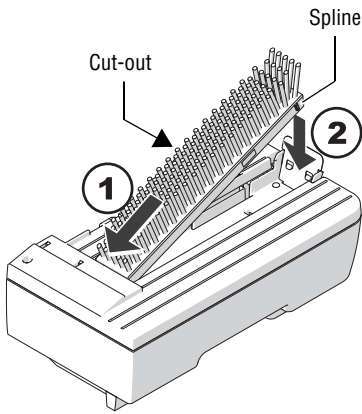

### Insert new transport brush

- Insert the new transport brush into the brush carrier like shown in the illustration (1).
- Push down the brush on the right side until it locks into place beneath the two catches (2).

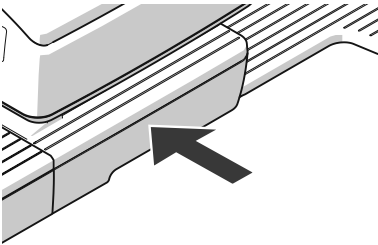

- Slide the drawer in to the stop. Make sure that the drawer latches correctly on both sides.



## 15.8 Calibrating the touch screen

You have to calibrate the touch screen when operating the screen with your finger or with the stylus does not work correctly.

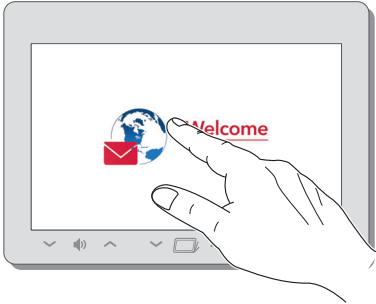

- Turn PostBase Vision on.

As soon as the screen displays the start animation:

- **Touch and hold your finger in the middle of the display** until the calibration procedure starts.

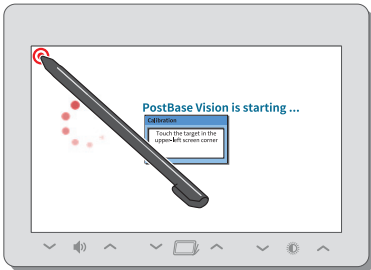

A red circle (the first calibration circle) appears in the upper left corner.

- Touch the red circle with the stylus.
- Follow the further instructions on the display: Touch each of the displayed calibration circles with the stylus.

PostBase Vision will continue its start routine. The touch screen is now calibrated.

## 15.9 PostBase Vision Feeder (optional)

### 15.9.1 Filling with sealing fluid

We recommend using the SEALIT sealing fluid. This special sealing fluid is available from FP or an authorized FP dealer.



**Warning! Electrical hazards due to short circuits.**

*Be extremely careful when handling fluids. If you fill the sealant tank, make sure not to dampen any parts connected to electronics. If this should happen, immediately pull the power plugs. Have the PostBase Vision mailing system checked by the Customer Support before using it again.*

---

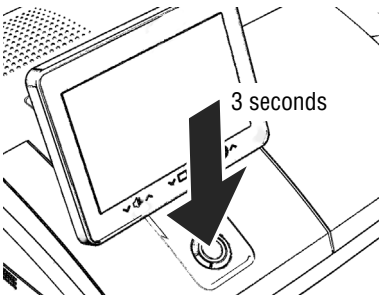

- Switch the mailing system off.

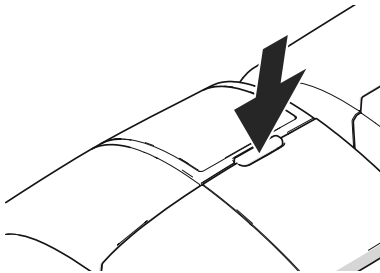

The sealant tank is located under the transparent flap. To open the flap:

- Press the key.

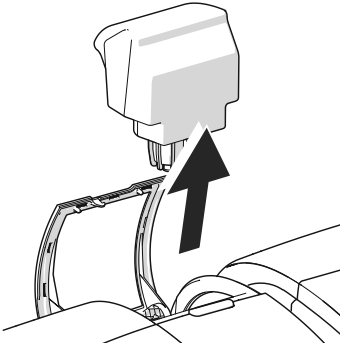

- Remove sealant tank out of housing.

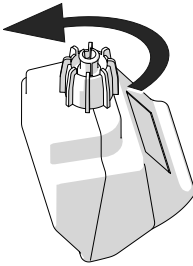

- Unscrew sealant tank cover.
- Fully empty sealant tank and, if necessary, clean it.

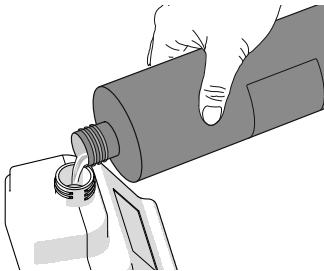

- Fill the sealant tank with SEALIT sealing fluid.

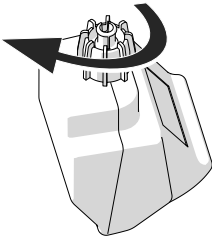

- Place sealant tank screw cover and tighten.
- Turn sealant tank upside down in a non-dangerous area (e.g. over a sink) to check if the cover is well sealed.

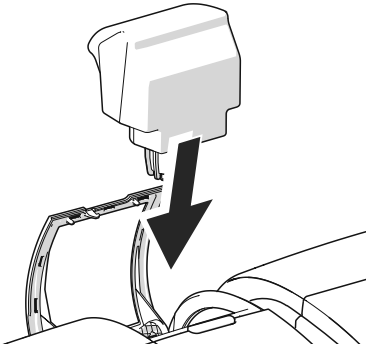

- Insert sealant tank into the housing with the cover downward.

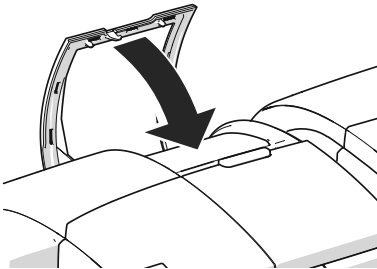

- Close the flap.

## 15.9.2 Adjust moistening level

With the help of the supplied spacer ring, the moistening level can be adapted to the letters accordingly. Depending on the position of the spacer ring, moistening of the envelope flaps can be reduced or increased.



### **Warning! Electrical hazards due to short circuits.**

*Be extremely careful when handling the sealant tank and tray to prevent spilling any fluids. Make sure not to dampen any parts connected to electronics. If this should happen, immediately pull the power plugs. Have the PostBase Vision mailing system checked by the Customer Support before using it again.*

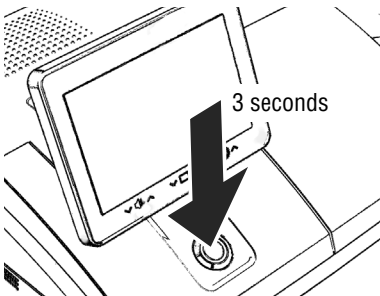

- Switch the mailing system off.
- Remove sealant tank out of the housing (for further information see chapter 15.9.1 on page 142).

At the rear of feeder:

- Carefully pull the sealant tray out to the back (see page 147).

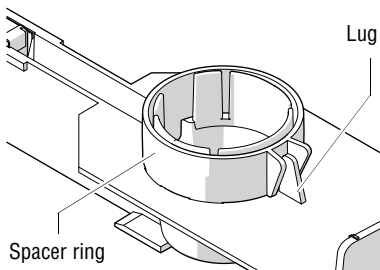

### **Normal moistening**

With this setting, you achieve best results in most cases.

- Position the spacer ring so that the teeth are facing down and the lug on the tray is placed between the guides. The teeth have to nip into the cut-outs of the tray.

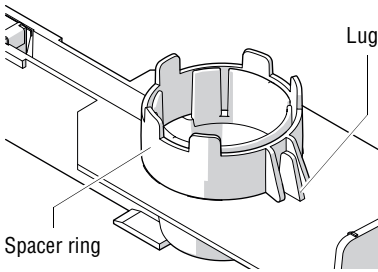

### Increased moistening

- Position the spacer ring so that the teeth are facing up and the lug on the tray is placed between the guides.
- Insert the sealant tray into the housing until it clicks into place (see page 148).
- Insert sealant tank into the housing with the cover downward. Close the flap. (See page 144.)

### 15.9.3 Cleaning / changing the moistening sponge

The sponge for moistening the envelope flaps should be cleaned regularly. Check the condition of the sponge and replace it if exhausted. We recommend always keeping a new sponge in reserve.



**Warning! Electrical hazards due to short circuits.**

*Be extremely careful when handling the sealant tank and tray to prevent spilling any fluids. Make sure not to dampen any parts connected to electronics. If this should happen, immediately pull the power plugs. Have the PostBase Vision mailing system checked by the Customer Support before using it again.*

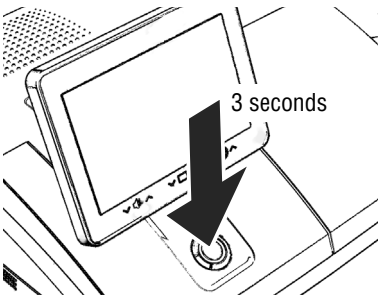

- Switch the mailing system off.

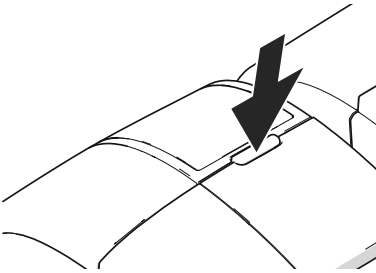

- Open the flap by pressing the key.

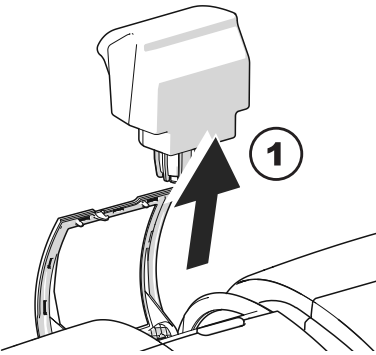

- Remove sealant tank out of the housing and put it at a safe place.

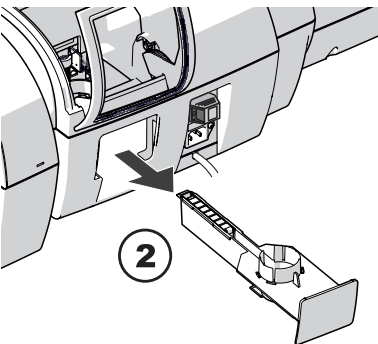

At the rear of feeder:

- Carefully pull the sealant tray out to the back.
- Empty sealant tray and, if necessary, clean it.

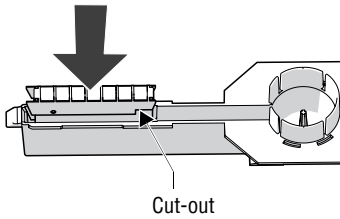
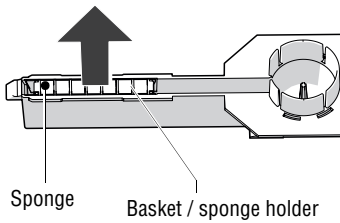

**Check:**

Basket on the extreme left

Basket flushed on top

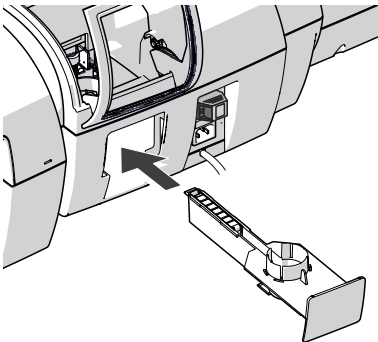
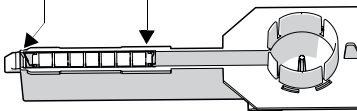

- Lift the basket with the sponge out of the tray.
  - Clean sponge or replace with a new one.
  - Put a new sponge (with basket / sponge holder) into sealing fluid before inserting it, and let it soak completely. The flaps are thus correctly moistened from the first letter on.
  - Carefully insert the basket with sponge into the tray until basket and tray are flush. Mind the position of the cut-out.
- 
- Check if the basket is correctly seated: It must rest on the extreme left in the tray and close on top in a flushed manner.
- 
- Insert the complete tray into the housing until it clicks into place.
  - Check if the sponge is correctly seated. It should be directly below the moistening felt and brush.



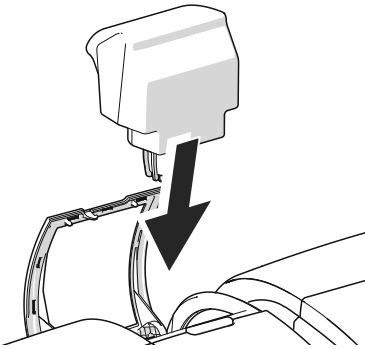

- If necessary:  
Fill sealing fluid into sealant tank. Check for leakages. (For further information see chapter 15.9.1, page 142.)
- Insert sealant tank into the housing with the cover downward.

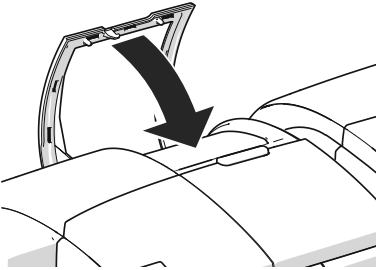

- Close the flap.

### 15.9.4 Cleaning / changing the moistening brush

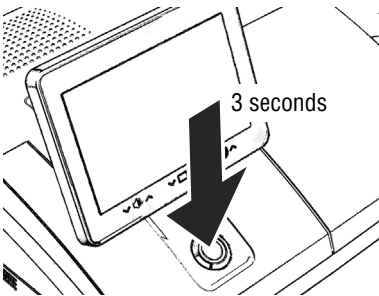

- Switch the mailing system off.

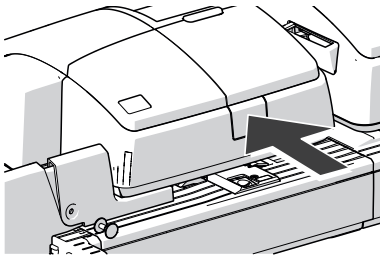

- Open the roller transport by pressing on the release button.

The roller transport moves upward.

Now you have access to the moistening brush beneath the roller support.

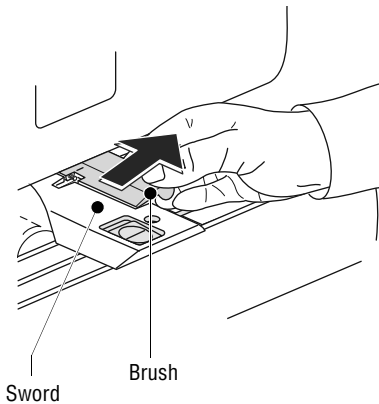

The brush is provided with pins on both sides that are snapped in clips on the sword.

- Slightly lift the brush and pull it off the sword in the direction of the arrow.

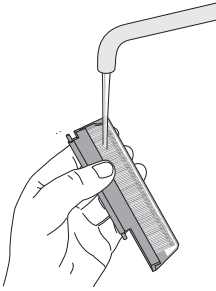

- Clean the brush or replace it with a new one.
- Moisten a new brush before inserting it.

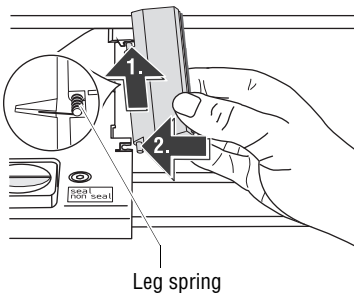

- Hold the brush as shown in the figure:
  - The bristles must face down.
  - One leg of the leg spring is located in the brush groove and the other leg in the sword slot.
- Put the rear pin into the clip of the sword as indicated by the arrow.
- Then carefully snap the front pin into the clip of the sword.

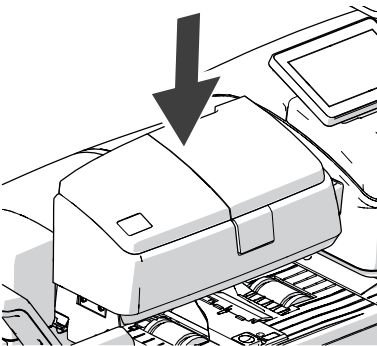

- Push the roller transport down powerfully until it locks into place.

## 15.10 Sealer *(optional)*

### 15.10.1 Cleaning

The sealer should be cleaned once a month to remove glue residues.

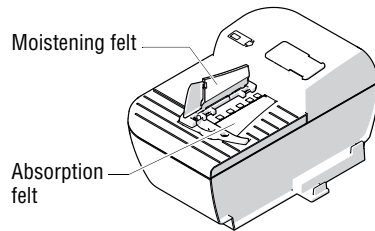
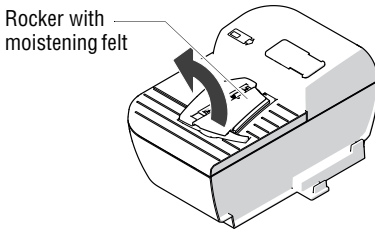

- Separate the sealer from the postage meter:  
Slightly lift the postage meter on the left side and pull the sealer away to the left.
- Swing up the rocker with the moistening felt.
- Thoroughly rinse absorption and moistening felts under running water.
- Wipe the housing with a damp cloth. You can also use a commercially available dishwashing detergent.
- Fill with sealing fluid (see page 153).
- Dry the sealer.
- Connect the sealer to the postage meter (see page 24).

### 15.10.2 Checking the fluid level and filling with SEALIT

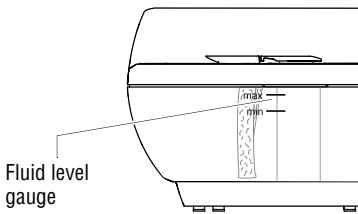

- Check the fluid level in the sealer regularly.

Make sure the sealer is always filled at least to the “min” mark to prevent the felts from drying up. When felts with glue residues dry up they harden to the point of becoming prematurely useless.

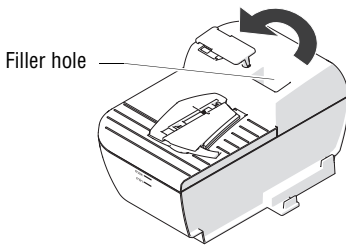

#### Filling with sealing fluid

We recommend using the SEALIT sealing fluid. This special sealing fluid is available from FP or an authorized FP dealer.

- Swing the filler hole lid aside.

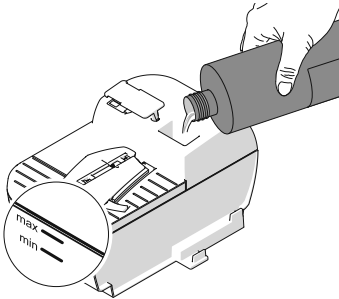

- Fill the sealer with SEALIT sealing fluid.
- Check the fluid level. The fluid level in the sealer should roughly reach to the “max” mark.

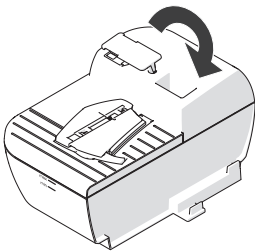

- Swing the filler hole lid back on.
- If necessary: dry the sealer outside.

### 15.10.3 Replacing felts

- Separate the sealer from the postage meter:  
Slightly lift the postage meter on the left side and pull the sealer away to the left.
- Empty the fluid reservoir.

#### Removing the rocker with moistening felt

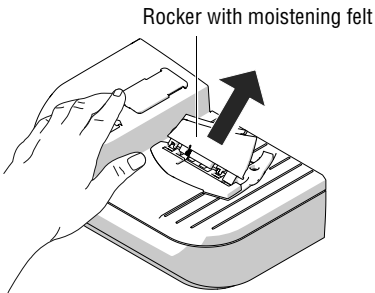

- Slightly tilt the rocker and pull it off in an obliquely upward direction.

#### Removing the absorption felt

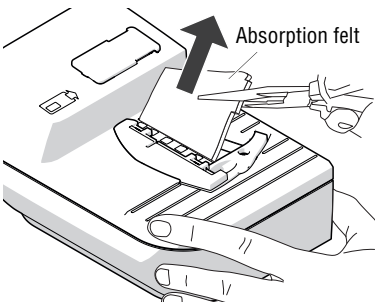

- Grip the absorption felt with pliers or tweezers and pull it out upwards.

### Installing the absorption felt

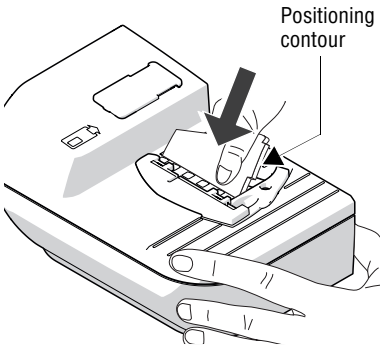

- Install a new absorption felt as shown in the illustration. The felt should be halfway in the sealer.

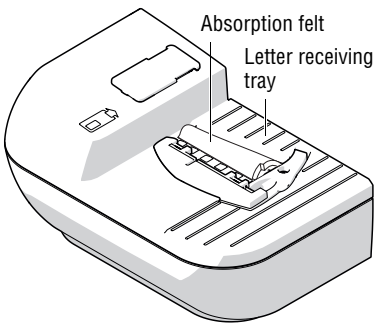

- Bend the upper part of the felt to the right and push it beneath the letter receiving tray until it reaches the stop in the contour.

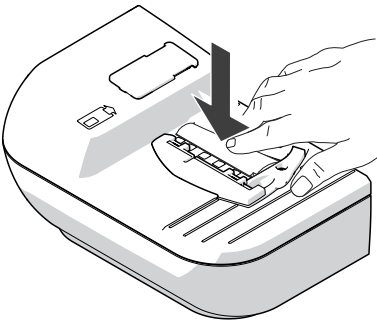

- Evenly push the arched absorption felt with your hand into the fluid reservoir. Make sure that the felt is correctly seated, in particular at the edges. The stop in the positioning contour must fit precisely in the opening of the letter receiving tray.
- As a final measure, stroke with your finger over the felt repeatedly to eliminate any irregularities.

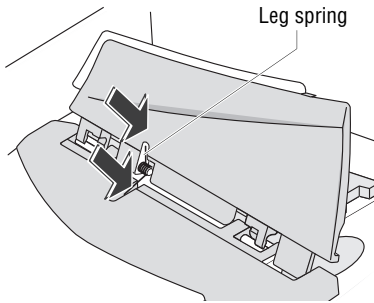

### Installing the rocker with moistening felt

The rocker features two clips that engage on the two bolts at the sealer.

- Fit the new rocker such that one leg of the leg spring is located in the rocker groove and the other leg in the sealer slot.
- Hold sealer in place, and exerting moderate pressure, push the rocker onto the sealer such that the two clips engage on the bolts.

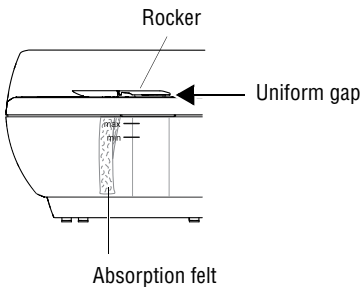
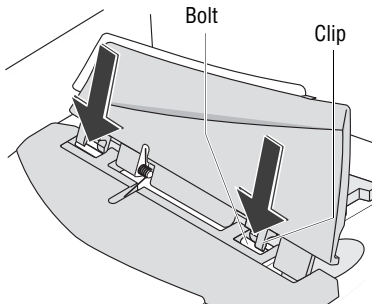

### Check

- Check the correct seat:
  - The absorption felt must be perpendicularly suspended in the fluid reservoir. Its lower edge should roughly reach the bottom.
  - The gap between rocker and sealer housing must be uniform. (The rocker must neither jut out nor touch the housing.)
- Fill with SEALIT sealing fluid (see page 153).
- Connect the sealer to the postage meter (see page 24).