

4 The basics of operation

In this chapter, you will learn the basic functions of the PostBase Vision mailing system and how to use the touch screen.

4.1 Turning the PostBase Vision on / off

The PostBase Vision mailing system can remain connected to the network at all times and is therefore always quickly ready for operation. Use the round button in front of the display to turn the PostBase Vision mailing system ON / OFF.

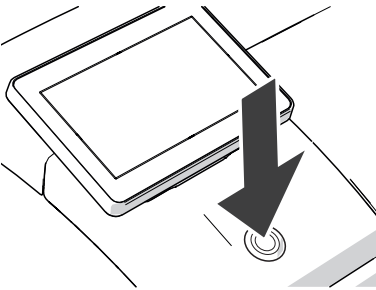

Turning on

- Press the ON/OFF button.

The LED lighting switches on and the system starts. The progress of the process can be followed on the display. PostBase Vision greets the user – acoustically accompanied – the display moves to the last position used and finally the Home screen appears on the display.

If access control is activated, you must enter your PIN during the start routine.

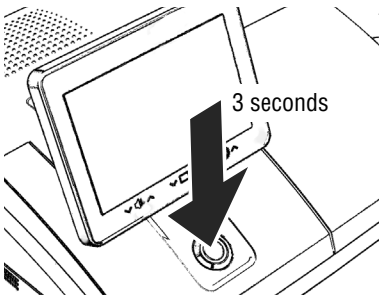

Turning off

- Press the ON/OFF button for three seconds.

The PostBase Vision will complete any current actions, return the display to its home position, and then turn itself off.

Note: The PostBase Vision requires daily connection to postal servers. You should allow the mailing system to remain in sleep mode and it will automatically wake up and connect during the night. Sleep mode is still an eco-friendly setting and PostBase Vision is EnergyStar 2.0 certified.

Disconnecting the PostBase Vision from mains



Caution! Make sure to always turn the PostBase Vision off with the ON/OFF button before disconnecting the PostBase Vision power cables. Never pull the power plug or separate the power supply in any other way before the printing system has reached its sealed position. This is the only way to prevent drying up and to ensure a permanently high print quality.

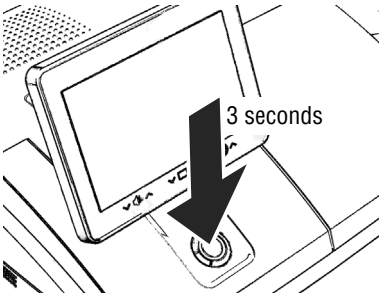

- Press the ON/OFF button for three seconds to turn the PostBase Vision off.

When the illumination is off:

- Unplug the power plug from the power outlet.

4.2 Standby (Sleep mode)

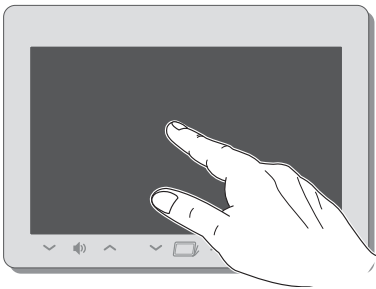

If you do not use the mailing system for a while, it automatically switches to Sleep mode (standby).

The display is dark and the ON/OFF button is illuminated in standby.

Briefly touch the display to “wake up” PostBase Vision.

As an alternative, you can briefly press the ON/OFF button.

4.3 Screen elements and operation philosophy

This chapter introduces the user interface of the PostBase Vision mailing system. You will learn how to use the touch screen, the screen elements and the various menus, window types and icons.

4.3.1 The touch screen

The touch screen of the PostBase Vision mailing system **reacts to pressure** (resistive display). With this type of touch screen, it does not matter whether you use your finger, fingernail, pen or gloves.

The touch screen supports different methods of operation: Tapping and Swiping. Depending on the desired action, you can select your preferred method.

Tapping

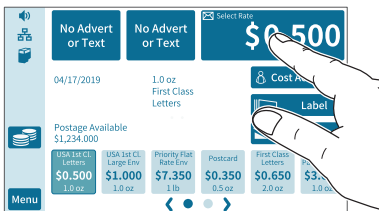

General operating instructions

- Briefly tap the desired element on the screen (in the example, this is the button with the postage).

PostBase Vision carries out the corresponding action (in the example, the rate selection / product calculation opens).

Swiping

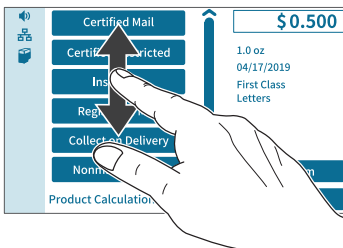

- For example, press your finger in the area where you want to navigate.
- Hold down the area and move your finger in the desired direction.

Operating scrollbars

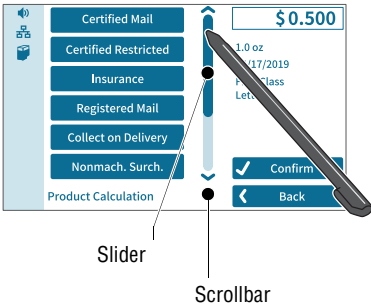

- Press the slider and move it in the desired direction.

You can also tap the arrows to scroll up or down the list.

Scrolling through lists

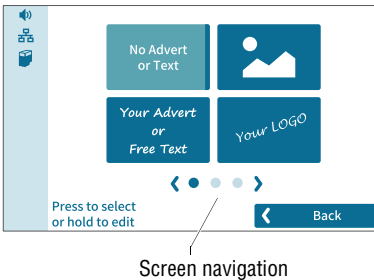

In menus and selection lists, dots symbolize the number of available screens (pages). The dark blue dot indicates the current screen.

- Tap the arrows to scroll through the list.
- Tap on a dot to jump directly to this screen.

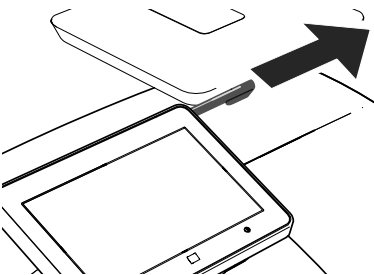

Stylus for touch screen operation

The supplied stylus for touch screen operation is located in the back of the display housing on the right. You can simply pull the stylus out to the right.



It is best to put the stylus back in its place in the display housing after use. It is well-protected from loss there.

Buttons

Buttons stand out from the background due to their color. Depending on their function, they can assume different states:



Button is active
(it can be tapped).



Button is active (it can be tapped).
This color is used for buttons with special functions, such as shortcuts.



Button is selected.



The button is currently being tapped.



Button is deactivated
(it cannot be tapped).

Standard buttons

The term “standard button” refers to the buttons SAVE, OK, CANCEL, BACK and CONTINUE.

The marking can vary depending on the function.

4.3.2 The Home screen

After turning on the unit and successfully completing the start routine, the Home screen appears on the display. It shows the current meter settings. The menu bar on the left of the window shows status information, e.g. volume, network connection and ink level, and provides access to additional functions.

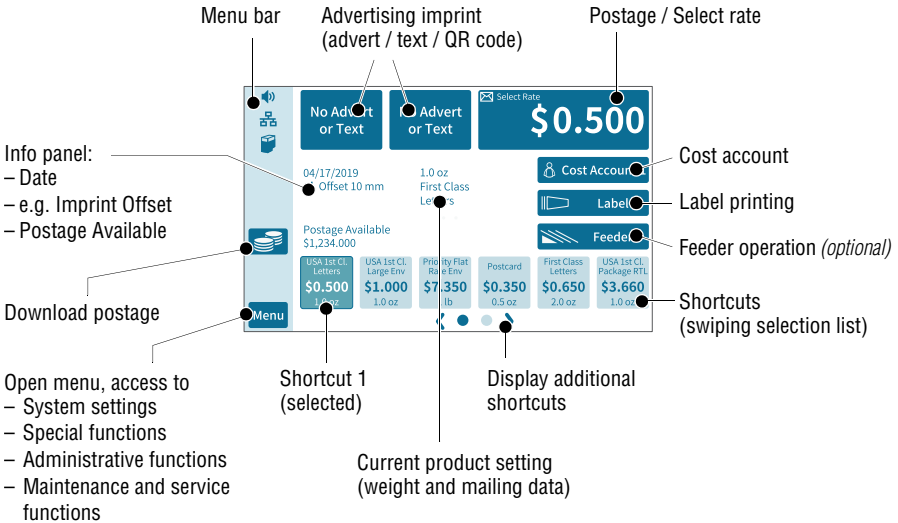

- Functions* In the Home screen:
- current settings are displayed
 - you have access to all settings relating to the meter imprint
 - you meter your mail pieces
 - you can weigh your mail pieces
 - you have access to additional functions using the buttons in the menu bar

- Operation philosophy* To select a function / setting, tap the button. Depending on the function selected, PostBase Vision then opens a selection list, a setting menu or a menu with additional selection options.
- You can also simply “swipe” the selection list with the shortcuts.

4.3.3 The menu bar

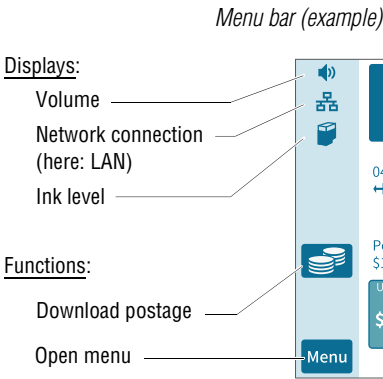

The highlighted area on the left of the window is the menu bar.

In the menu bar, you can see important status information at a glance, such as the volume of the sound signals, the type of network connection and the ink level in the cartridge.

In the Home screen, the menu bar also has buttons that give you access to system settings and other useful functions.

You can adjust the color of the menu bar according to your taste. Read more about it in chapter 14.6 on page 114.

4.3.4 The menu

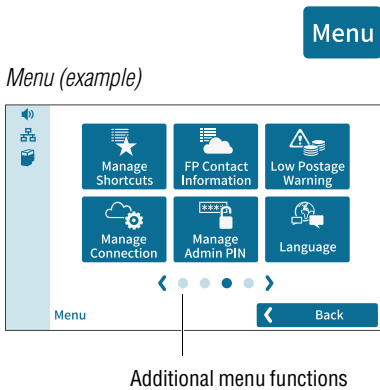

You can use the MENU button to open the menu in which you have access to the system settings, administrative functions, special features, and service functions.

Use the arrows to scroll through the menu.

By tapping the dots, you jump directly to the corresponding menu screen.

You can also move through the menu by swiping (to the right or left).

4.3.5 Selection lists

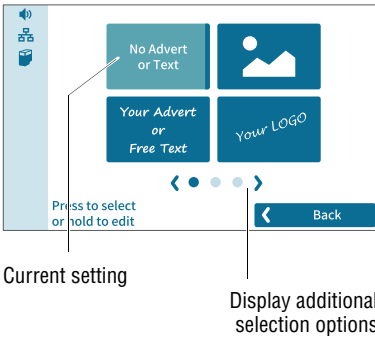

Selection lists (e.g. for adverts, printed text or QR codes) offer all available settings. The current setting is highlighted in color (light blue with a dark blue bar).

Use the arrows to scroll through the list.

By tapping the dots, you jump directly to the corresponding screen of the selection list.

You can also move through the list by swiping (to the right or left).

To apply the desired setting, tap the corresponding button.

4.3.6 Setting menus

A separate menu opens for adjusting and selecting settings. Setting menus are available in various versions, e.g. as a list with possible settings for selection or with a keypad for entering digits.

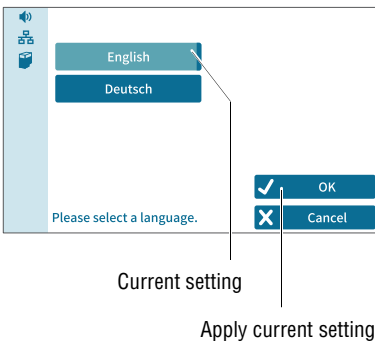

Lists

The left area shows the available settings. The current setting is highlighted in color (light blue with a dark blue bar).

If there are more than six choices, scroll or swipe the list.

Use OK to apply the current setting and exit the setting menu.

Use CANCEL to discard your entry and exit the setting menu.

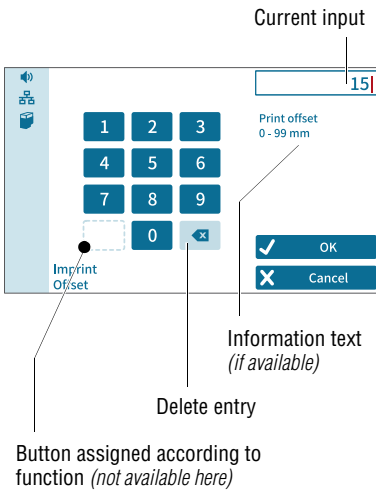

Input via numeric keypad

Use the keypad in the left area to input values. The display field at the top right shows your entry.

The keypad is always adjusted to the respective situation: If available, the bottom left button is assigned an operating action adjusted to the current function, e.g. entering a decimal point.

The information text provides information about special features and additional notes.

Use OK to apply the current setting and exit the setting menu.

Use CANCEL to discard your entry and exit the setting menu.

4.3.7 On-screen keyboard

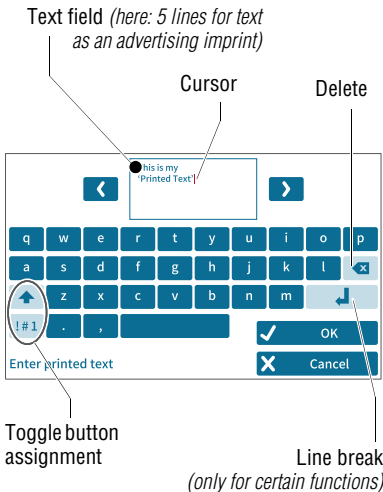

PostBase Vision opens the on-screen keyboard to enter text, numbers and special characters, e.g. for an individual text as advertising imprint, for entering shortcut names and searching cost accounts.

The entered text can be seen at the top of the display. Use the arrows to the left and right of the text field to move the cursor in the text. You can place the cursor directly at the desired text position by tapping it.

The on-screen keyboard allows you to enter letters, numbers and a number of special characters.

The buttons for switching the assignment are each adjusted to the current situation:



Enters capital letters.
Hold down for “Caps Lock”.



“Caps Lock” is active.
Switch off “Caps Lock”.



Switches to numbers, punctuation and special characters.



Scrolls (between the available special characters and digits).



Switches back to letters.

Use OK to apply the displayed text.

Use CANCEL to discard your entry and exits the text entry.

4.3.8 Pop-up windows

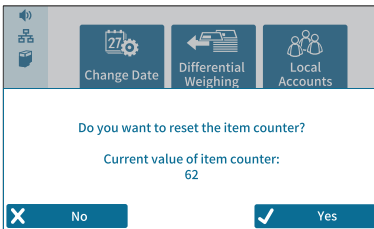

Some settings open a window that partially covers the current window (pop-up window). The pop-up calls for an action. Messages, label printing and batch processing with feeders also appear as pop-ups.

Some pop-up messages acknowledge themselves, i.e. after a certain time they disappear automatically.

4.3.9 Procedures / wizards

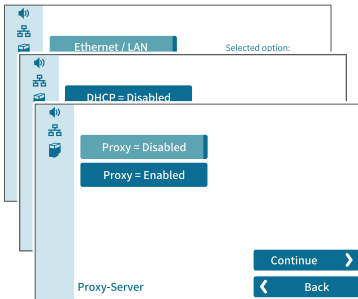

PostBase Vision guides you step-by-step through all the necessary entries for comprehensive settings, e.g. when configuring the network connection. Different window types are used depending on requirements.

Use CONTINUE to apply the current setting and proceed to the next step.

Use BACK to return to previous steps.

4.4 Adjusting the display angle

The display angle can be adjusted by using the motor. Simply press the sensitive areas to the left and right of the  icon on the display frame.

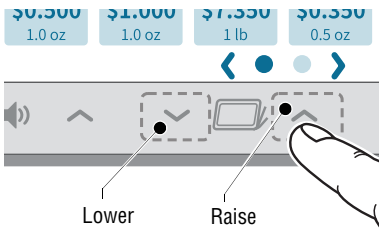

- Press and hold the desired function (raise / lower) until the display is in the desired position.

When turning off the unit, PostBase Vision lowers the display to its home position. When the unit is turned on, the display returns to the set position.

4.5 Adjusting the display brightness

You can adjust the brightness to your preferences to ensure good legibility of the display texts and best rendering of the contrasts. Simply press the sensitive areas to the left and right of the  icon on the display frame.

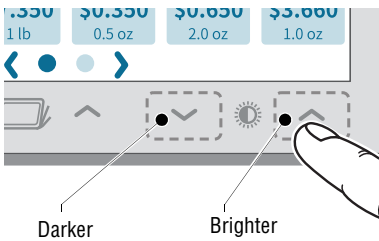

- Press and hold the desired function (brighter / darker) until the display shows the desired setting.

4.6 Adjusting the volume

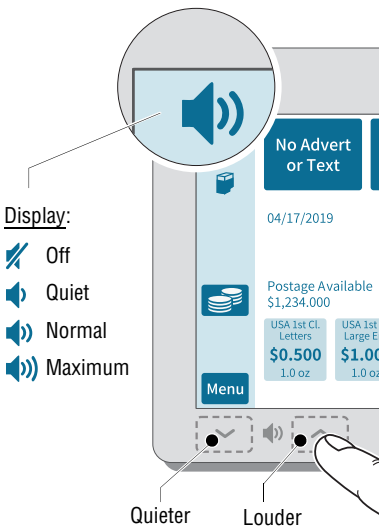

You can see the current volume setting for the sound signals in the menu bar at the top left.

To adjust the volume, press the sensitive areas to the left and right of the speaker icon on the display frame.

- Press and hold the desired function (louder or quieter) until the test signal is at the desired volume.

Turning off the speaker

- Turn the volume “down” until you see the  icon.

Note: The sound signal volume when the system starts is fixed and cannot be changed.

4.7 Inserting labels

! **Caution!** We recommend to use only labels that have been approved by FP. The manufacturer FP has established reliability, safety and applicability. The manufacturer cannot assess the reliability, safety and applicability for products not approved by FP, and therefore not vouch for such products. We can ensure correct label processing only when you comply with this.

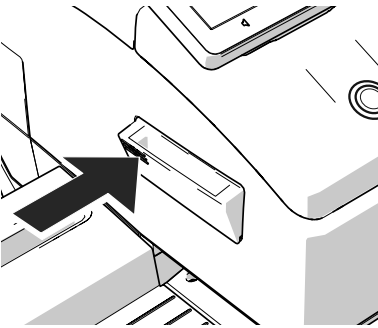

To fold the label compartment out:

- Press on the knurled surface until you hear a click, then release.

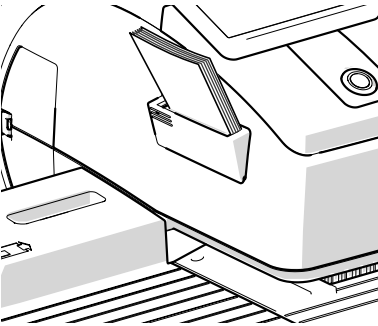

- Remove package band from the package of labels.
- Insert the complete package (50 labels) in the label compartment:
 - The side to be printed on faces up.
 - Insert the package of labels in direction of the imprinted arrow as far as it will go.

4.8 Setting up the catch tray

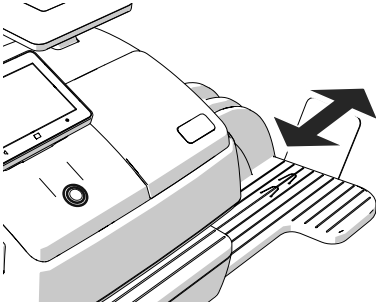

The catch tray can be adapted to different envelope sizes (up to 10" x 14") by displacing the catch bracket.

The stop features several catches for the most common sizes.

4.9 Using the High Capacity Drop Stacker (optional)

The Drop Stacker, which is available from FP as an optional additional component for the PostBase Vision mailing system, is placed instead of the catch tray to the right of the postage meter. Retrofitting the PostBase Vision with the Drop Stacker is also very easy. Especially for larger quantities of outgoing mail, the Drop Stacker with a capacity of up to 250 letters (*#10 envelope containing one sheet 8.5" x 11" 20 pound bond paper*) is a practical alternative to the letter catch tray.

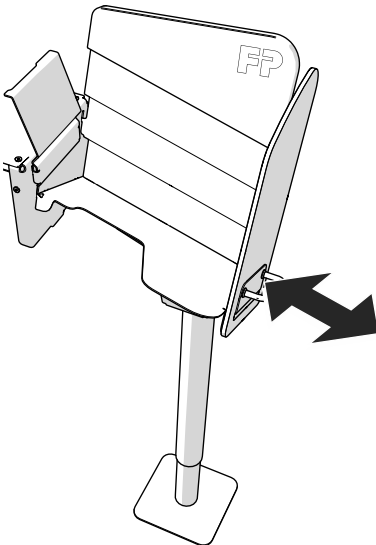

Installation

- Install the Drop Stacker according to the assembly instructions. (The detailed assembly instructions for the Drop Stacker are included in the package).

Adapting to the envelope format

- You can move the right side wall in direction of the arrow using the handle. Catch points, which are spaced apart by approx. 0.6" / 15 mm allow adjustment to match the different envelope formats.

To remove the letter stack ...

Thanks to the specially shaped shaft bottom, the carefully stacked mail pieces can be easily accessed from the bottom and removed stackwise, even when the machine is running.