

## 2 A short description of the PostBase

### 2.1 PostBase franking machine – overview

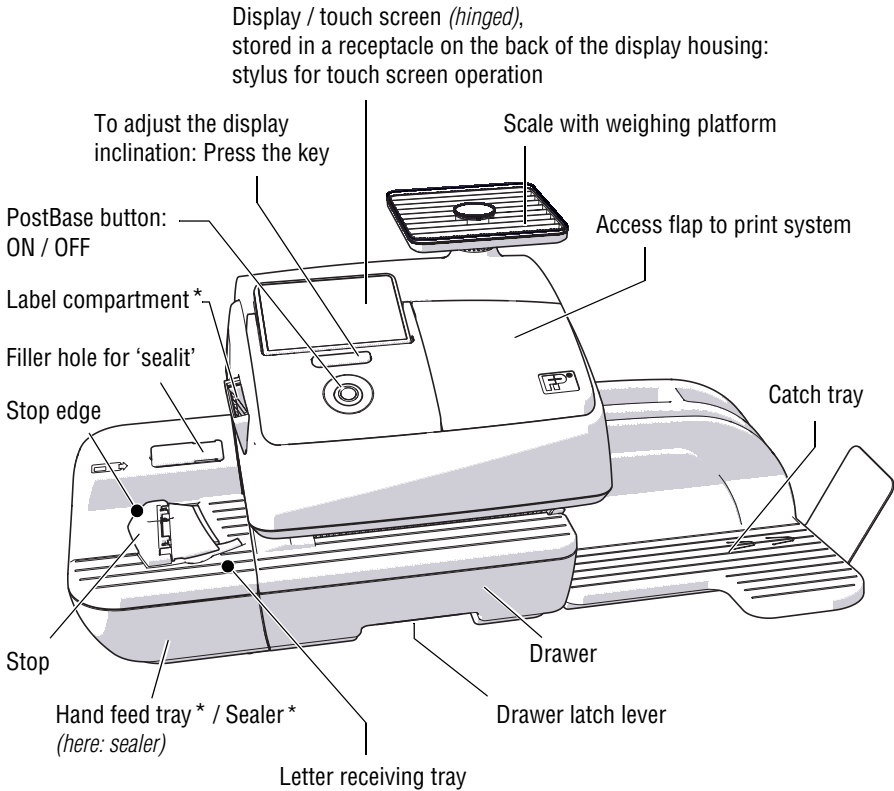

\* optional / not all product variants

### Franking machine – rear view

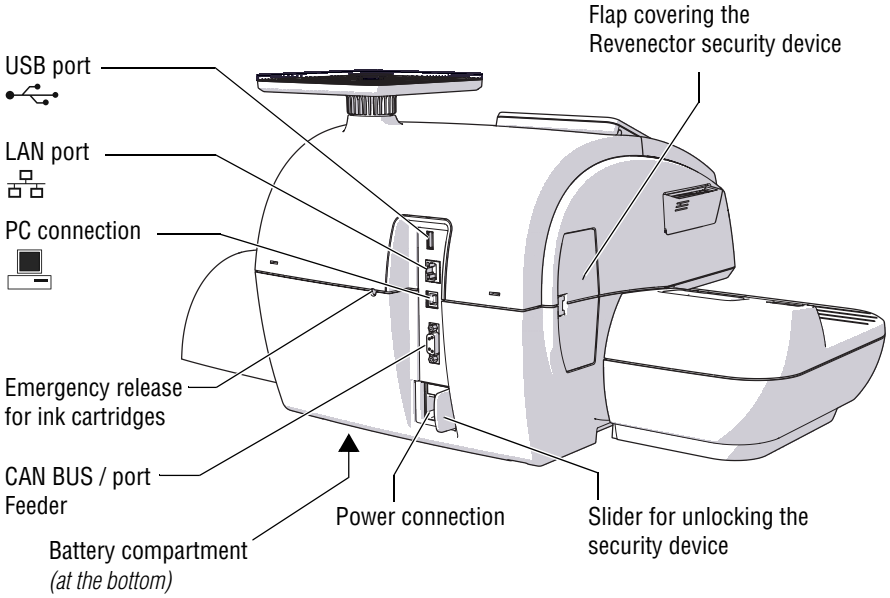

## 2.2 Feeder – overview *(optional)*

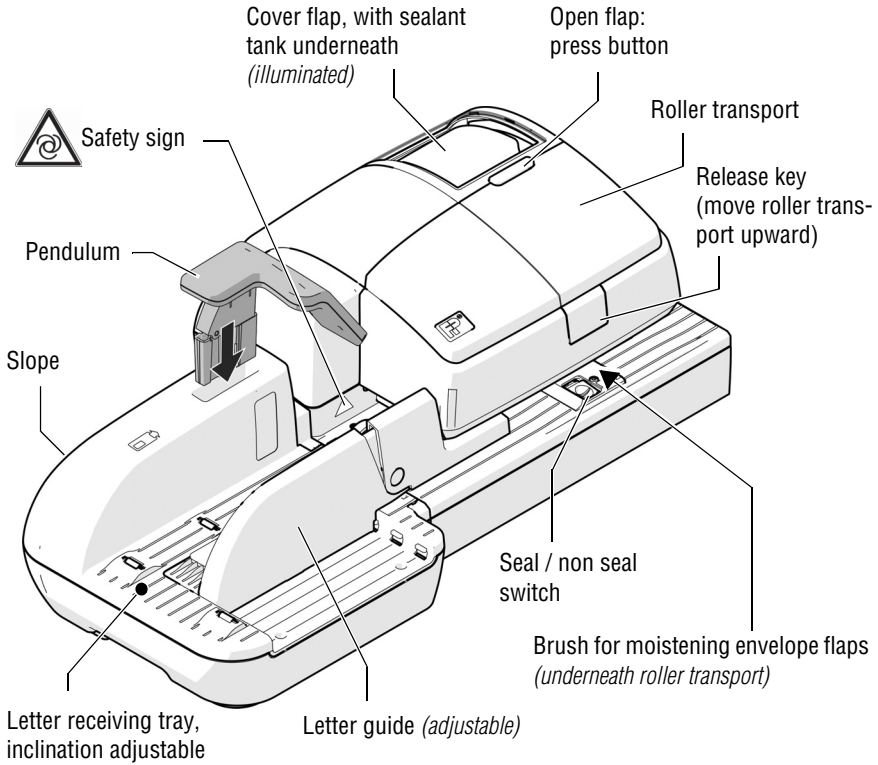

### Feeder – rear view

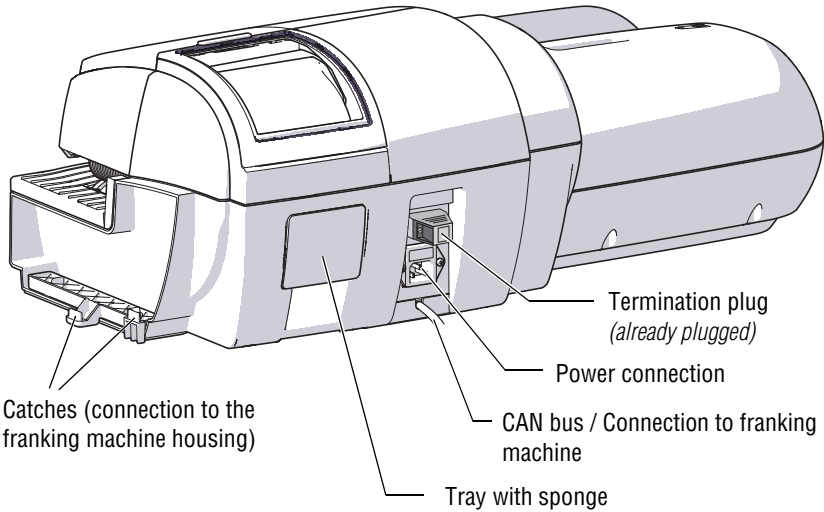

(View without pendulum)

## 2.3 Things worth knowing about PostBase

### *Modular design*

PostBase is a digital mailing system featuring a touch screen and ink-jet print technology.

In its basic version, the mailing system consists of the PostBase franking machine with integrated scale, a hand feed tray and a letter catch tray.

This basic version can easily be extended with optional components.